

IMPORTANT SAFETY INSTRUCTIONS

INSTALLATION, OPERATING AND SERVICE MANUAL

READ AND FOLLOW ALL INSTRUCTIONS

BADUJET

Counter Swim Unit

U.S. Patent No. 3.977.027

OWNER'S MANUAL

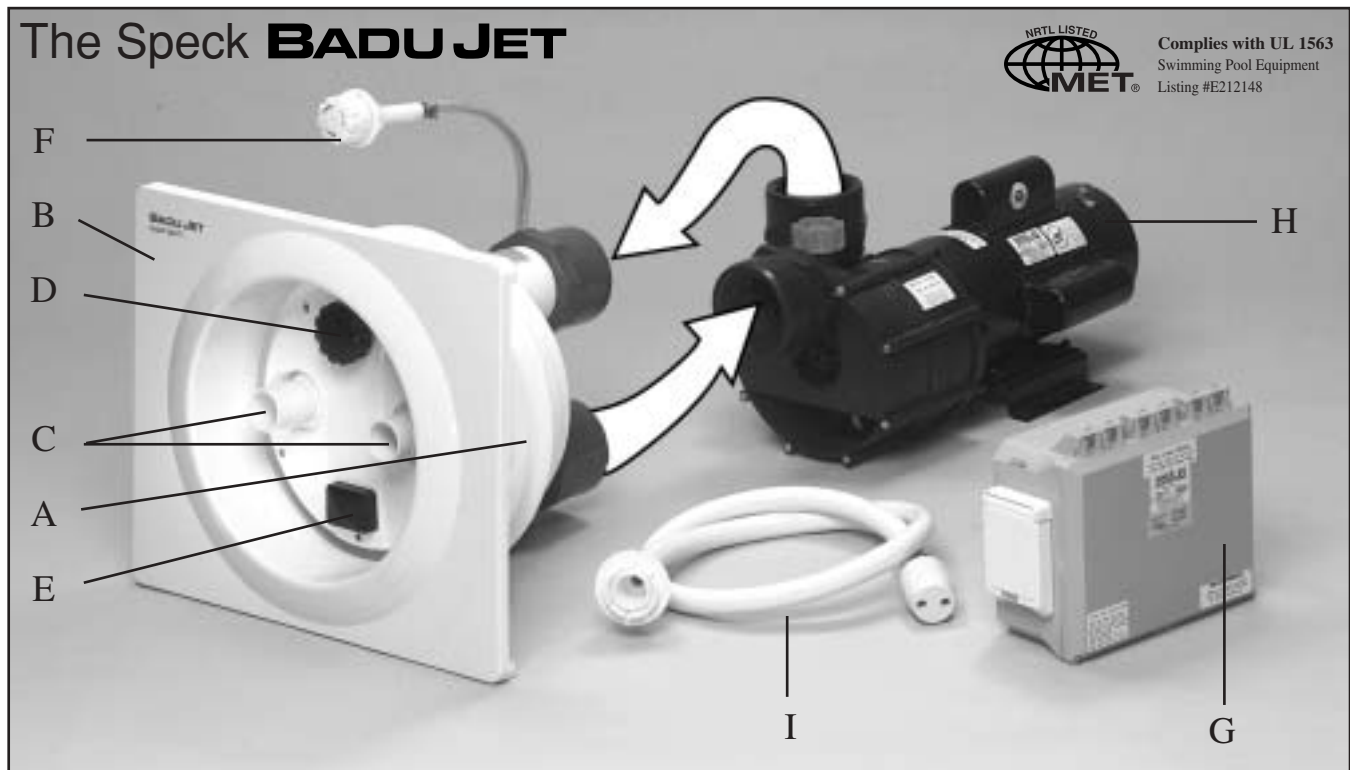

This is the **BADUJET** super-sport

All parts are manufactured of corrosion-resistant material and combined in one single housing that can be installed in pools of any size and shape.

Key to illustration:

- A. Flush mounted Jet Housing, 16" in diameter
- B. Rectangular, anti-vortex cover (20x17") for undetectable suction (optional round cover available for curved pool wall)
- C. Adjustable recessed jet nozzles
- D. Water volume control knob adjusts force of water leaving jet nozzles
- E. Pneumatic on/off button guarantees complete electrical separation between pool water, pump motor and control box
- F. Air regulator adjusts amount of air bubbles in water flow
- G. Control box with GFCI with tubing for pneumatic button
- H. Speck 4 HP self-priming, plastic pump, single phase with thermal overload (no motor starter required) Optional three phase motor and control available (Normal priming pump available for installation below water levels)
- I. Massage hose with pulsator may be attached to jet nozzle.

1 . Important Safety Instructions

When installing and using this electrical equipment, basic safety precautions should always be followed, including the following:

A. READ AND FOLLOW ALL INSTRUCTIONS.

B. **▲ WARNING** : To reduce the risk of injury, do not permit children to use this equipment unless they are closely supervised at all times. Failure to adhere to this and all other warnings could result in serious injury or death.

C. A licensed electrician is required for all wiring connections.

D. **TO REDUCE RISK OF ELECTRICAL SHOCK**, connect all ground wires to grounding terminal located in the control box. Use no smaller than a No. 12 AWG (3.3 mm²) wire.

E. **TO REDUCE RISK OF ELECTRICAL SHOCK**, a bonding connector is provided on the motor for bonding of local ground points such as water pipes, metal ladders/handrails, or other metal within 5 feet of the pool. All local ground points should be bonded with a No. 8 AWG (8.4 mm²) wire. Never use gas piping as an electrical ground.

F. All electrical equipment should be installed in accordance with local codes.

G. **DO NOT** store or use gasoline or other flammable vapors or liquids in the vicinity of this equipment. **DO NOT** store pool chemicals near the equipment.

H. **DO NOT** remove any safety alert labels such as **DANGER**, **WARNING**, or **CAUTION**. Keep safety alert labels in good condition and replace missing or damaged labels.

I. Keep and read all equipment manuals. Adhere to all of their instructions.

J. **▲ WARNING** : Stay alert, watch what you are doing and use common sense. **DO NOT** use unit if you are tired and/or exhausted. Do not use unit while under the influence of drugs, alcohol, or any medication.

K. **▲ WARNING** : Consult your physician before exercising with the **BADUJET** or using the massage hose.

L. **▲ WARNING**: **DO NOT** use or operate the **BADUJET** if the rectangular (or optional double round) anti-vortex cover is missing, broken or loose.

M. **SAVE THESE INSTRUCTIONS!** Refer to them frequently and use them to instruct third party users.



2. Introduction and Planning

The **BADUJET** is normally incorporated into the original pool design. However, it can be added to any pool at a later date.

The **BADUJET** has no protruding parts, ensuring the pool user's safety. It is very compact and installs at minimal cost.

The **BADUJET can be installed in any size pool.** We suggest a minimum pool size of 7 ft. wide, 14 ft. long and 3 1/2 ft. deep in order to swim. Most prefer 16 ft. in length or longer. The extra length allows the swimmer to comfortably drift back and swim up stream.

Consult local codes for minimum distance between pump and pool. Locate pump as close to the

BADUJET as practical.

Use at least 4" pipe when distance between jet housing and pump is 30 ft. or less and 6" pipe for runs longer than 30 ft.

The 4 HP, self-priming, plastic pump has a single phase motor with thermal overload (no motor starter required). The 4 HP single phase motor draws a maximum of 19.4 amps at 230 V. The unit requires a minimum circuit of 30 amps. Install a 40 amp breaker to avoid nuisance tripping when the pump is turned on and off frequently. The starting current of the 4 HP motor can reach up to 6 times the running currents. (Three phase motor draws a maximum of 12.8 amps @ 230 V and 6.4 amps @ 460 V.)

3. Plumbing for **BADUJET**

The **BADUJET** assembly package contains all necessary parts for the installation of the unit into concrete, gunite, liner or fiberglass pools.

▲ CAUTION : All necessary screws and bolts included with the **BADUJET** are stainless steel or plastic. **ALL** screw threads and threaded inserts are **METRIC! ONLY METRIC** screws, bolts and nuts may be used! The one exception is the connecting thread for the intake and delivery connections on the **BADUJET** and pump housing. These are 3" NPT threads and 4" slip. **Use only 4" slip for **BADUJET**.**

▲ CAUTION : The adapters on the housing are factory mounted and should never be removed. Removal of these adapters will void warranty.

▲ CAUTION : The pressure connection must be located exactly **ABOVE** the suction connection.

▲ CAUTION : **The center of the housing (the two nozzles) should be 10" BELOW water level for maximum efficiency.** The air regulator should be approximately 4" **ABOVE** the water level. (See fig. 1.)

CAUTION : The suction line should be run below water level right up to the pump location.

CAUTION : For trouble-free pump priming (up to 4 ft.) first install a 6" riser on top of the pump. Then install an elbow and lead the pressure line downward to the pressure connection at the **BADUJET** housing.

CAUTION : Throughout the entire installation, make sure the plumbing connected to the **BADUJET** housing is well supported. Unsupported plumbing will crack the **BADUJET** housing.

CAUTION : In areas with soft soil conditions or with frequent earth movement, a flexible section of 4" hose should be attached to the back of the Jet housing to prevent plumbing breakage.

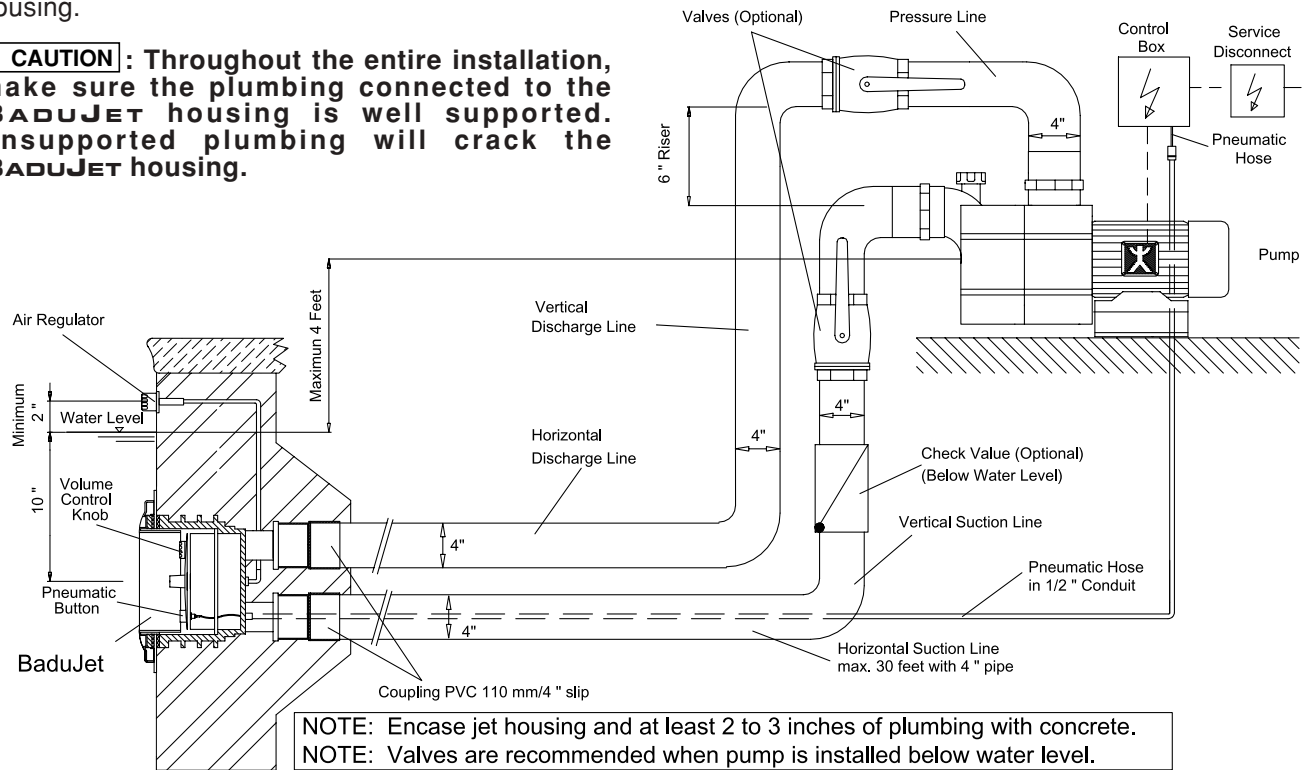

Fig. 1

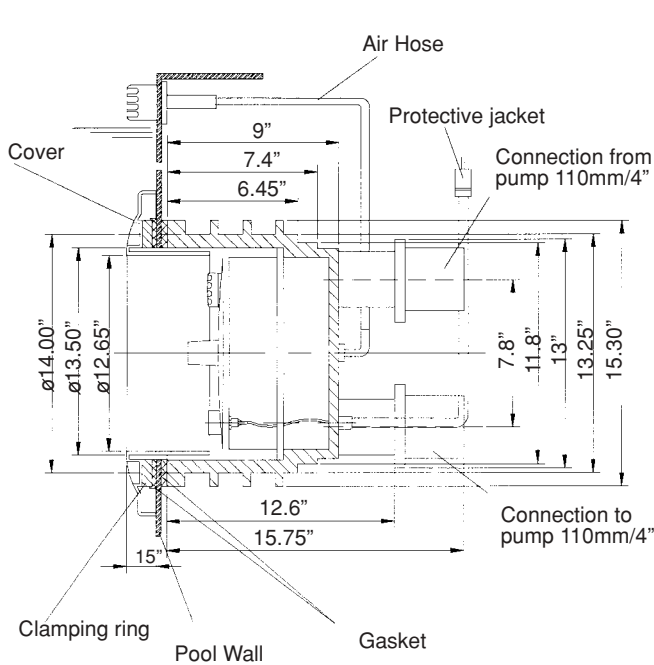

Fig. 2

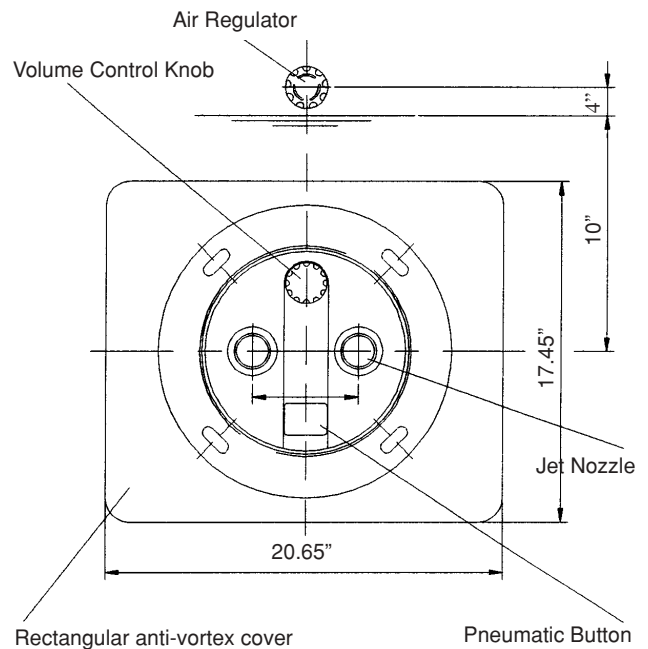

Fig. 3

4. Concrete or Gunite Installation

A. Preplumb **BADUJET** Housing

1. Install the two PVC SCH 80 couplings 110 mm/4" slip (#2a) on the PVC SCH 80 fittings 110 mm (#2) which are premounted on the jet housing.

2. Install approximately 12" of 4" SCH 40 pipe to both suction and discharge couplings on the jet housing. NOTE: If plumbing exceeds 30' between jet housing and pump, increase pipe size to 6". Install a 6x4" reducing bushing as close to jet housing as possible.

3. Install approximately 18" of 1/2" conduit to back of jet housing. (Conduit connector part # 3).

4. Install air control PVC hose (part # 7) and Y socket (part # 6) assembly to hose socket insert fittings (part # 4). Use hose clamps (part #8) to secure hose to insert fitting.

B. Mount the protective cover plate (part # 30) to jet housing using stud bolts M8x80 (part # 31). Tape edge of cover plate to jet housing. The cover plate and stud bolts are solely used for installation and can be discarded afterwards. Keep concrete out of threaded inserts and out of the inside of the housing.

C. Place jet housing into reinforced steel. (See fig. 7.) Jet housing location is very important.

1. Locate pressure connection exactly above the suction connection. Pressure and suction connections must be exactly vertical or the rectangular cover will be uneven in appearance.

2. The center of the housing (the two nozzles) should be 10" BELOW water level for maximum efficiency.

3. Front edge of Jet housing should finish even with inside gunite wall. Make sure a V shaped groove is scraped out around the housing approximately 1 1/2" deep to allow marcite to seal against the housing.

4. Recheck location of Jet housing when gunite is being applied. The force of the gunite may move the jet location.

5. To avoid stress on the jet housing, we recommend that the **BADUJET** housing be encased with gunite and at least 2 to 3 inches of the plumbing stub out is covered with gunite. **NOTE: Stress on the plumbing may crack the **BADUJET** housing.**

D. Air regulator installation should be approximately 4" ABOVE the water level.

1. Air regulator holder (part # 9) and hose socket insert fitting (part # 5) connect to PVC hose (part # 7). Make sure air regulator holder face is taped over to prevent gunite from entering holder.

2. Air regulator can be located in the tile line above water line or in the deck.

E. Keep all parts not being used now in original box. Store in a safe place until needed.

F. The following is a list of all parts that ARE NOT USED IN A GUNITE INSTALLATION:

- | | |
|-------------------------|------|
| 1. Gasket w/knobs | # 26 |
| 2. Clamping ring gasket | # 27 |
| 3. Counter sunk bolt | # 10 |
| 4. Washer M6 | # 12 |
| 5. Nut M6 | # 11 |
| 6. Counter sunk bolt | # 98 |

Fig. 4 Template for installation in gunite or concrete pools.

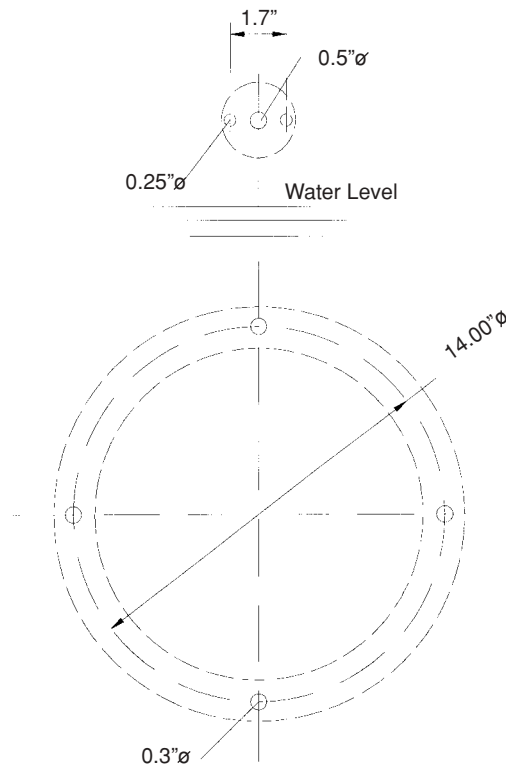
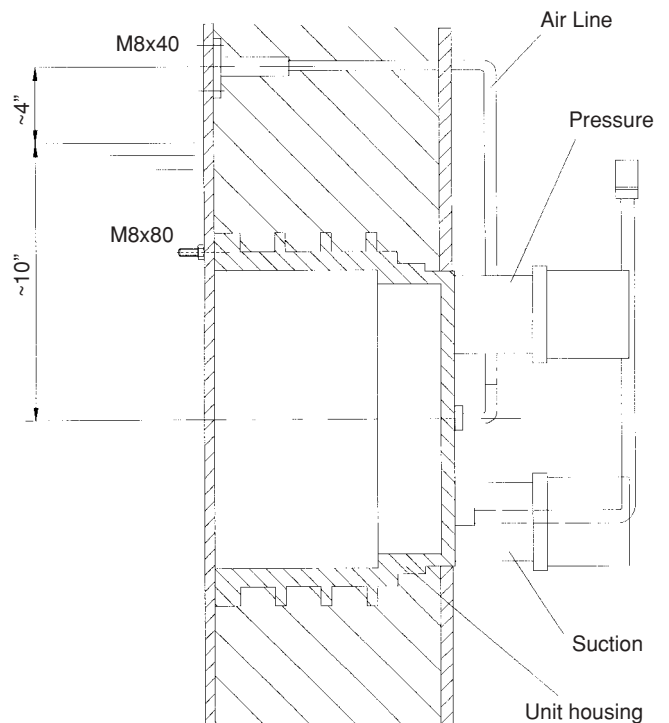

Fig. 5 **BADUJET** in concrete or gunite pool.



4a. Installing **BADUJET** in existing gunite or concrete pool

Materials: 1 piece Plywood 2'x3'x1/4"
8 Lag screws 1/4" x 1 1/2"(minimum)
8 Plastic lag anchor shields

Step 1. Carefully choose the location in which **BADUJET** is to be installed; it should be a flat surface with no or very little crown.

With a concrete saw, cut out the outline of the section to be chiseled out with an air hammer or equal. This hole should be 19" wide x 19" down from the water line. The bonding rods on the cap of the pool should be left intact, while all other steel rods should be cut back to clear the placement of the jet housing.

Step 2. Taking the 2'x3'x1/4" plywood, set its top edge even to the cap of the pool wall. In some cases a larger piece of plywood may be needed to cover the hole completely. If plywood covers the hole, mark the water line on the plywood. From this line, layout and drill holes in plywood for the air regulator, the four **BADUJET** housing installation studs, and the eight 1/4" lag screws. NOTE: See fig. 5a for layout measurements.

Insert installation studs (part # 31) in jet housing; one at the top, the bottom of the vertical center line and on each side on the horizontal center line. Place cover plate on studs covering the inside of the jet housing. Next place plywood on the studs and secure with washers and nuts.

Now place this assembly into position in the pool wall and align the water line marks. With a level on the two horizontal studs, level the assembly and mark the 8 holes for the 1/4" lags. Remove assembly and drill holes for lag anchors. Reposition the assembly and secure lags. It is best to check with a level before tightening the lags down. Back fill and form the outside of pool wall.

Step 3. Mix compound that is compatible and has good bonding characteristics to the pool wall compound. Pour mixture into form. Use a mallet and lightly tap the front of formed assembly to settle mixture, and avoid any air bubbles in the pour. It should be filled to the top of the plywood. Let mix cure and then remove plywood form and cover plate. Drill out plastic lag anchors and feather in pool wall finish. Replace tile and coping. Remove assembly studs and install nozzle housing and anti-vortex cover. (See sections 6 & 7.)

Throughout the entire installation, make sure the plumbing connected to the **BADUJET** housing is well supported. Unsupported plumbing will crack the **BADUJET** housing. To avoid stress on the plumbing, we recommend that the **BADUJET** housing be encased with gunite and at least 2 to 3 inches of the plumbing stub out is covered with gunite. Stress on the plumbing may crack the housing.

Fig. 5A Layout for installing in existing gunite or concrete pools.

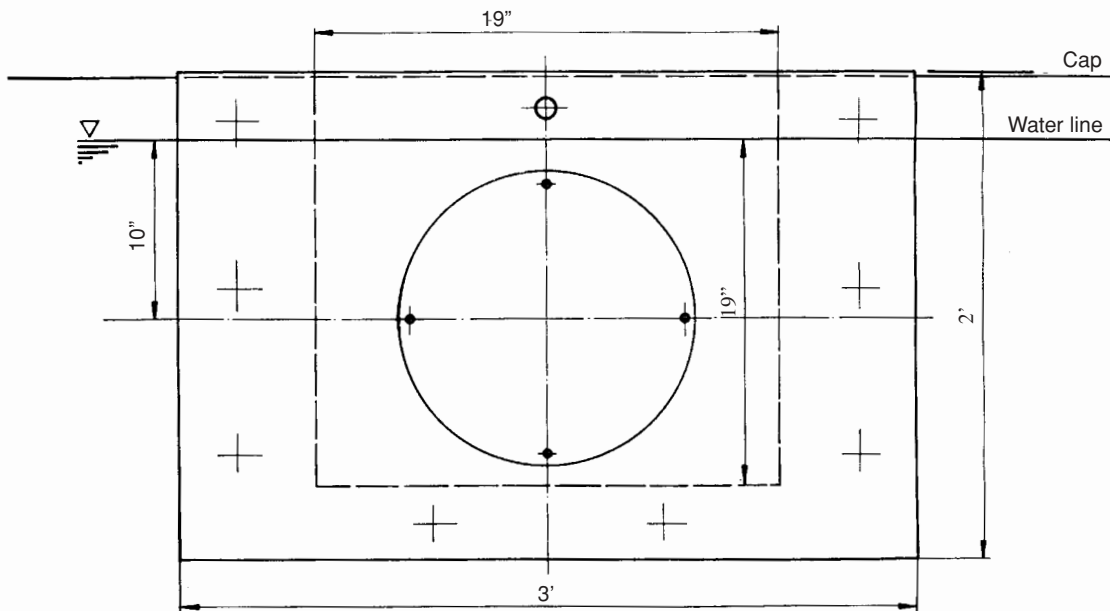

5. Liner and/or Fiberglass pool installation

▲ CAUTION : Locate the pressure connection exactly above the suction connection. Pressure and suction connectors must be exactly vertical or the rectangular cover will be uneven in appearance.

▲ CAUTION : Center of Housing (the two nozzles) should be 10" BELOW water level for maximum efficiency.

▲ CAUTION : Gasket with knobs (part # 26) goes **BEHIND** pool wall.

▲ CAUTION : Clamping ring gasket (part #27) goes in **FRONT** of pool wall. A good RTV silicone may be used with gasket when mounting jet housing, but in most cases is not necessary. Installer should decide whether or not silicone is necessary.

The template provided should be used to mark and drill the holes as shown in fig. 6. For the air regulator, one 1/2" hole must be provided, preferably along the vertical axis, approximately 4" ABOVE the water line.

For Liner pools only, two additional 1/4" holes need to be made on either side of the 1/2" hole. (See fig 6.)

Use the two countersunk bolts M6 (part # 10), two nuts (part # 11), and two washers (part # 12) to fasten holder to wall with bolt heads on poolside and nuts on backside. This will keep the holder attached to pool wall for liner installation or replacement.

NOTE: Gasket (part # 13) with larger holes on the outside, fits over screw heads between inside of pool wall and liner. This gasket may be held in place with silicone during liner installation.

F. The list below shows all parts that ARE NOT USED IN A FIBERGLASS/VINYL LINER INSTALLATION:

- | | |
|--------------------|------|
| 1. Cover plate | # 30 |
| 2. Stud bolt M8x80 | # 31 |
| 3. Washer M8 | # 32 |
| 4. Nut M8 | # 33 |

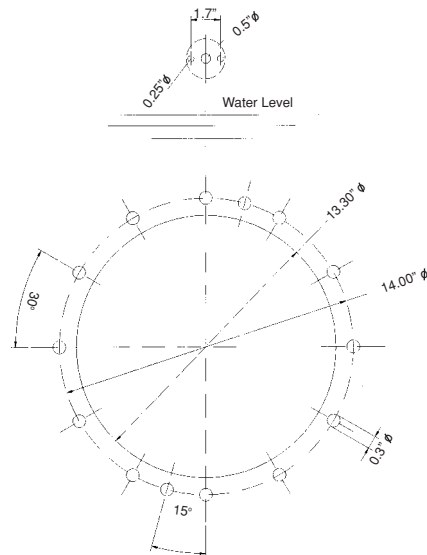

Fig. 6 Cutout in Pool Wall for **BADUJET** Housing
The two holes at 15° from the vertical axis and the two holes at the air regulator will allow both housing and air regulator to be mounted with countersunk screws (M8 Jet housing/M6 air regulator) before the

5a. Removal of Liner

When replacing liner or removing liner for repairs; remove 4 bolts (part # 95) which hold square cover (part # 93) to jet housing. Remove all bolts (part # 29) except top two, which hold the clamping ring (part # 28) and gasket (part #27) to the jet housing. Back out the two remaining bolts approximately halfway and check for any movement of jet housing from the wall. (NOTE: If the two counter sunk bolts (part # 98) which hold the jet housing to the wall were installed, the jet housing should not move, and the two remaining bolts can be removed.)

Remove one of the remaining two bolts and slide clamping ring (part # 3) to the side. Replace all the bolts before removing the last bolt. Remove or replace liner. Reverse process to install liner.

NOTE: When replacing clamping ring and bolts; locate bolt heads under liner, make small cut on liner at the bolt heads and push liner over bolt head.

6. Installation of Nozzle Housing

Make sure **BADUJET** housing and threaded inserts are clean. Nozzle housing can be mounted once the pool is complete. Pull the volume control knob off the spindle (snap connection). Remove nozzle cover.

Unscrew control disk (part # 63) from control spindle. Slide disk on to the 4 prongs at the top of the housing in front of the pressure connection.

VERY IMPORTANT: Make sure shaft side of disk faces nozzle housing (part # 53).

Connect air tubing (part # 47) to air button (part # 38/1) and secure with stainless steel clamps provided. Use end crimper/cutter to gently tighten clamps. **DO NOT OVERCRIMP.**

Insert preassembled nozzle housing with jets and control spindle in the jet housing. Turn control spindle counter-clockwise into the regulator disk.

Important: Make sure the o-rings (part # 62) on the small air tubes of the housing fit properly.

Important: Make sure the nozzle housing snaps elastically into jet housing.

Screw in the 12 bolts (M8 x 30) (Part # 52) to mount nozzle housing. Screw in the ten M8 x 130/25 bolts (Part # 51) to the center section of the nozzle housing.

Pass pneumatic hose through 3/4" hole in the bottom of the housing and through the 1/2" PVC conduit.

Make sure the end of the 1/2" PVC conduit containing the air tubing ends above the water level and is sealed off with gasket and nut (parts # 16-20) to avoid air intake through the conduit.

Important: Use ALL screws & bolts to guarantee absolute stability. Tighten all screws and bolts snugly. Insert screws & bolts carefully to avoid damage to the inserts.

Attach cover plate to nozzle housing with the 5 self tapping screws (Part # 49). The volume control knob and cap for air button can now be snapped into place.

7. Installation of Anti-Vortex Cover

CAUTION : This unit has a rectangular, anti vortex cover. Mount rectangular cover onto the clamping ring (part # 28) with four (4) bolts

(M8x20) and cover the openings with the rectangular covers (part # 96). The longer stainless steel bolts (M8 x 80) must be used if a distance has to be bridged when tiles are attached to the concrete.

OPTIONAL - Original round style, double ring, anti-vortex cover available for curved pool walls.

CAUTION : (For original round style, double ring, anti-vortex covers only.) This unit is equipped with two ring covers. The shallow ring with four attached bushings mounts over the deeper ring. Four plastic counter sunk bolts secure the two rings to the jet housing.

The ring covers should be fastened directly to the **BADUJET** housing with four (4) plastic bolts (M8x45).

CAUTION : **DO NOT** use force when tightening these plastic screws. Allow ring covers to snap into place elastically and snugly. The longer stainless steel bolts (M8x100) must be used if a distance has to be bridged when tiles are attached to the concrete.



Fig. 8 **BADUJET** Ready for Guniting

Fig. 7 Setting the **BADUJET** Housing into the Reinforced Steel

8. Installation of the Pump and the Control Box

⚠ CAUTION : Before installing the Speck Pump Model 21-80/33, read the entire pump owner's manual found in the pump box.

Consult local codes for minimum distance between pump and pool. Locate pump as close to the pool as practical.

The air button works up to 50 ft. There is 50 ft. of air tubing in **BADUJET** box. An adaptor (part # 81) is provided when additional tubing needs to be used in the event of replacing a section with locally purchased air tubing.

⚠ WARNING : To reduce the risk of injury, do not permit children to use this product unless they are closely supervised at all times.

The wiring of the pool motor and control box should be done by a licensed electrician in accordance with local codes. Be certain that the motor frame and control box are grounded. Motor name plate has voltage, phase, amp draw and

other motor information as well as wiring connection instructions. NOTE: Use 40 amp breaker.

BONDING: As required by National Electrical Code Article 680-22, the pump motor must be electrically bonded to the pool structure (reinforced bars, etc.) by a solid copper conductor not smaller than No. 8 AWG via the external copper bonding lug on the pump motor.

GROUNDING: Permanently ground the pump motor and control box using a conductor of appropriate size. Connect to the No. 10 green headed ground screw provided inside the motor terminal box.

NOTE: Do not connect to electric power supply until unit is permanently grounded.

Section 8 concerns the electric motor and control box only since all other parts, the pump, the jet unit, etc. have complete and absolute separation from the pool water.

9. Operation Instructions

Remove red filler plug on pump and fill pump with water. Replace red filler plug. Push pneumatic button on **BADUJET** housing. For the first start-up allow approximately 5 minutes for the pump to prime. If the pump has not started priming after 5 minutes, the amount of water in the pump was insufficient. Add more water.

BADUJET's volume control knob enables the swimmer to regulate the volume of water released through the jets. Turn unit off before turning volume control knob. (Turn clockwise to reduce flow up to 12 complete 360 degree rotations.)

The swivel nozzles of the **BADUJET** can be positioned in various directions, allowing swimmers to use various swim styles.

To start swimming, jogging or running it is suggested that the two nozzles are pointed slightly inward and slightly upward so that the water "breaks" approximately 3 ft. in front of the **BADUJET**. Start swimming with only minimal force in arms and legs until you feel yourself drifting backward, then add force and swim upstream until a proper balance is found between force and endurance.

Keep in mind that this unit is designed for a balanced workout. Find a pace that you can keep up for at least 20 minutes. Outpacing is always possible. The idea is to continue exercise for an extended period of

time.

Consult your physician before attempting any strenuous exercise. This product may not be challenging or satisfying for all levels of exercise.

The air regulator permits a controlled mixture of air into the water flow and creates a unique, invigorating, bubble bath effect. It will also add additional resistance to swim against.

A pulsating massage hose can be attached to one of the nozzles for massages.

Directions for use: Consult your physician before using the massage hose. To reduce the risk of injury, do not permit children to use the massage hose with pulsator unless they are closely supervised at all times. Turn **BADUJET** off. Close air regulator. Reduce the volume of water by turning the volume control knob clockwise, slide the cap (part # 50) on one nozzle and lock into place. Slide cap of massage hose on the second nozzle and lock into place. Hold pulsator and turn **BADUJET** on. Massage as advised by your physician.

Under certain conditions it is possible that the current "drifts off" to the left or the right from the middle due to water bouncing off the back wall. In the event that it interferes with your swimming actions, turn unit off for a few minutes and restart.

⚠ WARNING : Do not use or operate the **BADUJET** if the rectangular, anti-vortex cover or original round style, double ring, anti vortex cover is missing, broken or loose.

10. Winterizing

In areas subject to freezing water temperatures, protect pump by removing drain plug and red filler

plug. Drain pool until water level has dropped below the rectangular or round cover (part # 93).

Exploded View for BADU-JET Super Sport

Part #	Qty.	Description
1	1	Jet Housing
2	2	Adaptor - Male, PVC 2-1/2" X 90/110 mm
2a	2	Coupling, PVC 110 mm x 4"
3	1	Adaptor - Male, PVC 1/2"
4	2	90° Hose Fitting - Air Regulator, Plastic 1/4"
5	1	Fitting - Hose, Air Regulator, Plastic 1/4"
6	1	Y-Fitting - Air Regulator
7	1	Hose - Air Regulator 8 X 3mm (1.4meters)
8	6	Clamp - Hose, Air Regulator 14/9 SS
9	1	Holder - Air Regulator
10	2	Bolt - Air Holder, Slot/pan M6 X 30 mm SS
11	2	Nut - Air Holder, M6 SS
12	2	Washer - Air Holder, M6 SS
13	1	Gasket - Air Holder 60 X 11 X 2 mm
16	1	Adaptor - Female, PVC 1/2"
17	1	Adaptor - Male, PVC 1/2"
18	1	Ring - Hose 313/7

Part #	Qty.	Description
19	2	Washer SS
20	1	Plug - Rubber 7mm
21	1	Top Part - Air Regulator
22	1	Bottom Part - Air Regulator
23	1	Bolt W/hole - Air Regulator, Brass M10 X 80
24	1	Ring - Hose, Air Regulator 16 X 30 X 18mm
25	1	Gasket - Air Regulator 42 X 11 X 2mm
26	1	Gasket with Knobs - Jet Housing
27	1	Gasket - Clamping Ring
28	1	Ring - Clamping
29	12	Bolt - Clamping Ring, slot M8 X 30 SS
30	1	Cover - Gunite
31	4	Stud - Gunite Cover, All Thread, Zinc M8 X 80
32	4	Washer - Gunite Cover, M8
33	4	Nut - Stud, Gunite Cover M8 SS
38/1	1	Pneumatic Button (White)
40	1	Nut - Pneumatic Button, Plastic
43/1	1	Cover - Nozzle
46	1	Clamp - Hose, Pneumatic Button 8.7 mm
47	1	10 M Air Tube 4 X 1.5 mm (Per Meter)
49	5	Tapping Screw - Nozzle Cover, Phil. 4.8 X 19 SS
50	1	Volume Control Knob
51	10	Bolt - Nozzle Housing, Slot M8 X 130 SS
52	12	Bolt - Nozzle Housing, Phillips M8 X 30 SS
53	1	Housing - Nozzle
54	2	Nozzle - 40 mm
55	2	I T Gasket - Tension Cup 103 X 81.5 X 0.6 mm
56	2	Seat - Nozzle
57	2	Spacer - Nozzle 6.2 mm
58	2	Spacer - Nozzle 1 mm
59	2	Tension Cup - Nozzle
60	8	Washer - Lock, Tension Cup M6 SS
61	8	Nut - Tension Cup M6 SS
62	2	O-ring - Tension Cup 11.3 X 2.4mm
63	1	Volume Control Disc
64	1	Control Spindle
67	1	Retainer - Shaft, Control Spindle
68	8	Bolt - Tension Cup, Phillips M6 X 25 SS
80/1	1	Control Box BJC-7-GFCI
84	1	Cap - Nozzle, Close off
89	1	Massage Hose 5 ft. With Pulsator
89/1	1	Massage Hose 15 ft. With Pulsator (optional)
93	1	Cover - Rectangular
94	4	Washer - Rectangular Cover M8 SS
95	4	Bolt - Rectangular Cover, Slot M8 X 20 mm
95/1	4	Bolt - Rectangular Cover, Slot M8 X 80 mm
96	4	Plug - Rectangular Cover
97	1	Cover - Button
98	2	Bolt - Jet Housing, Slot/Pan M8 X 30 mm SS

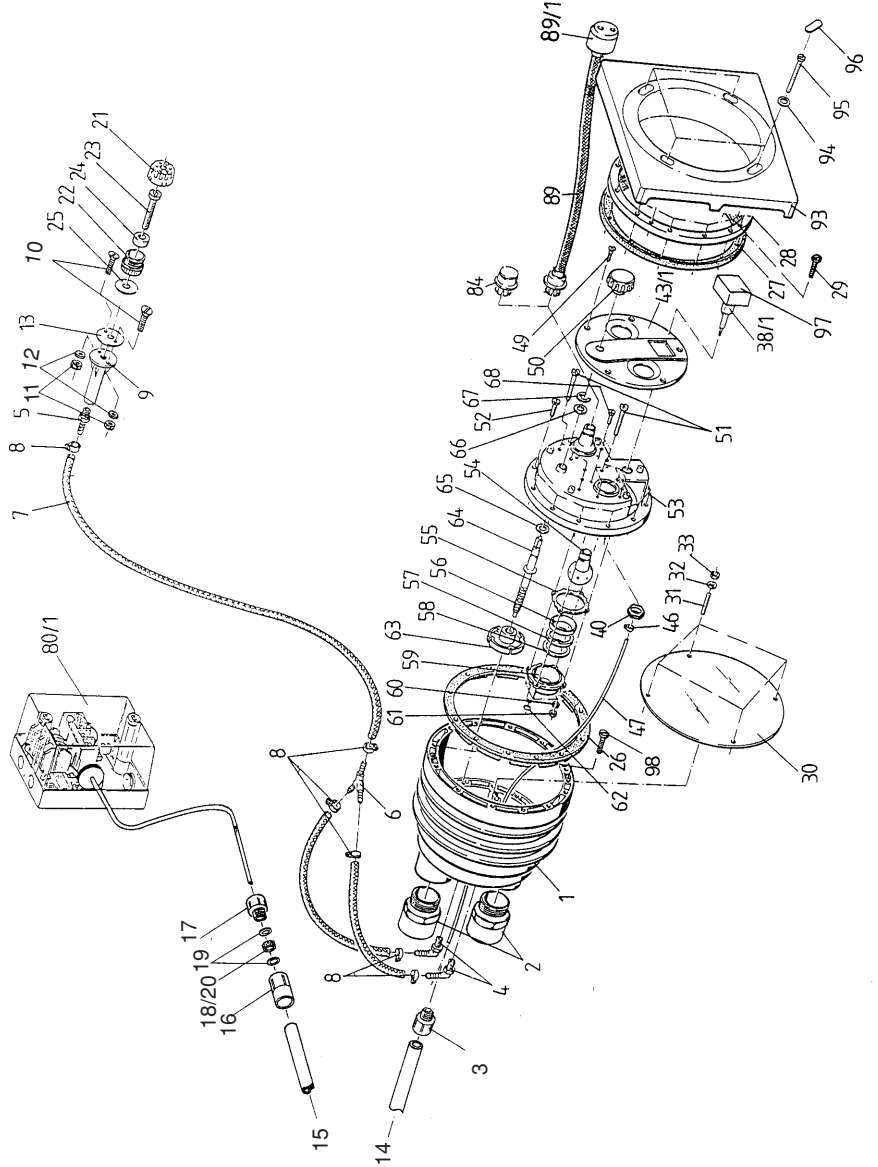

BADUJET CLASSIC

Differences between the BADUJET super-sport and BADUJET Classic

General:

The **BADUJET CLASSIC** is smaller in diameter (12" instead of 16"). It has only one jet and no regulator knob to adjust the flow of water.

1. Plumbing the **BADUJET CLASSIC**

The center of the housing should be 11.5" (instead of 10") BELOW water level for maximum efficiency. The suction and discharge line may be 3" instead of the 4" required for the large unit.

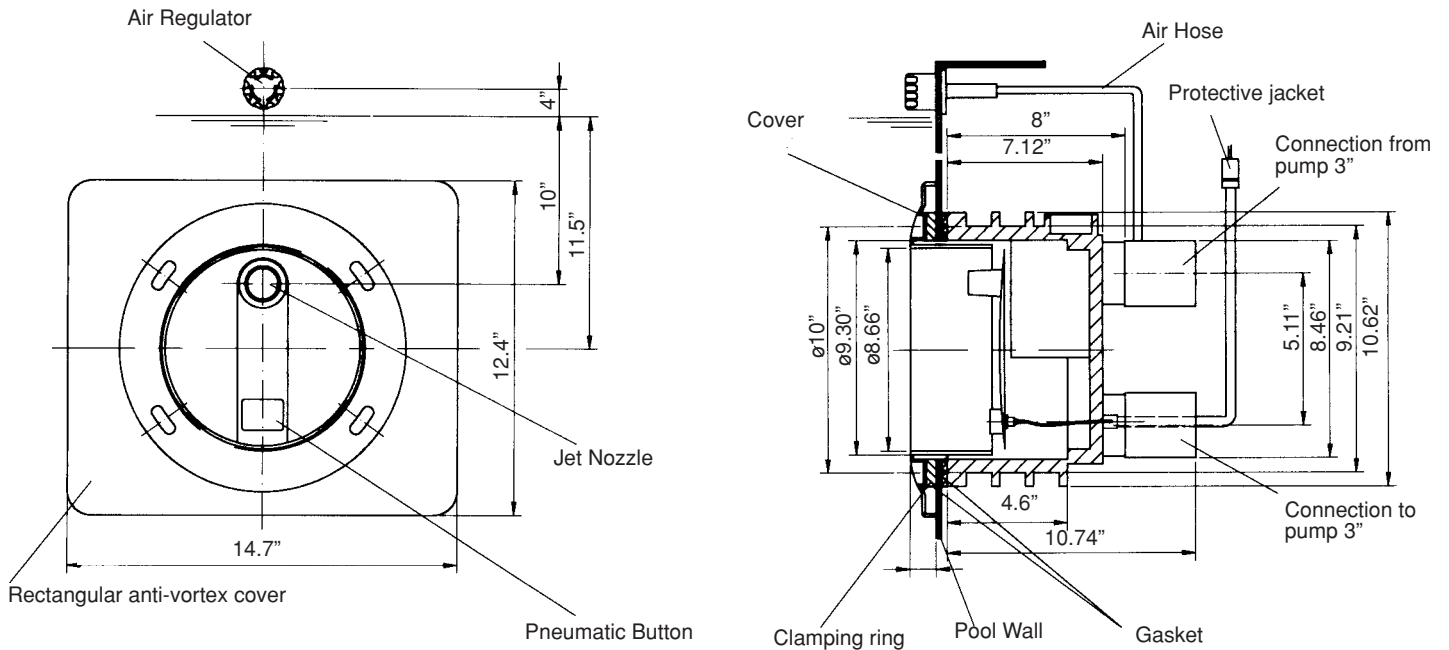

Fig. 2 & 3

2. Concrete or Gunite Installation

The screws used to mount the ring cover are M6 instead of M8.

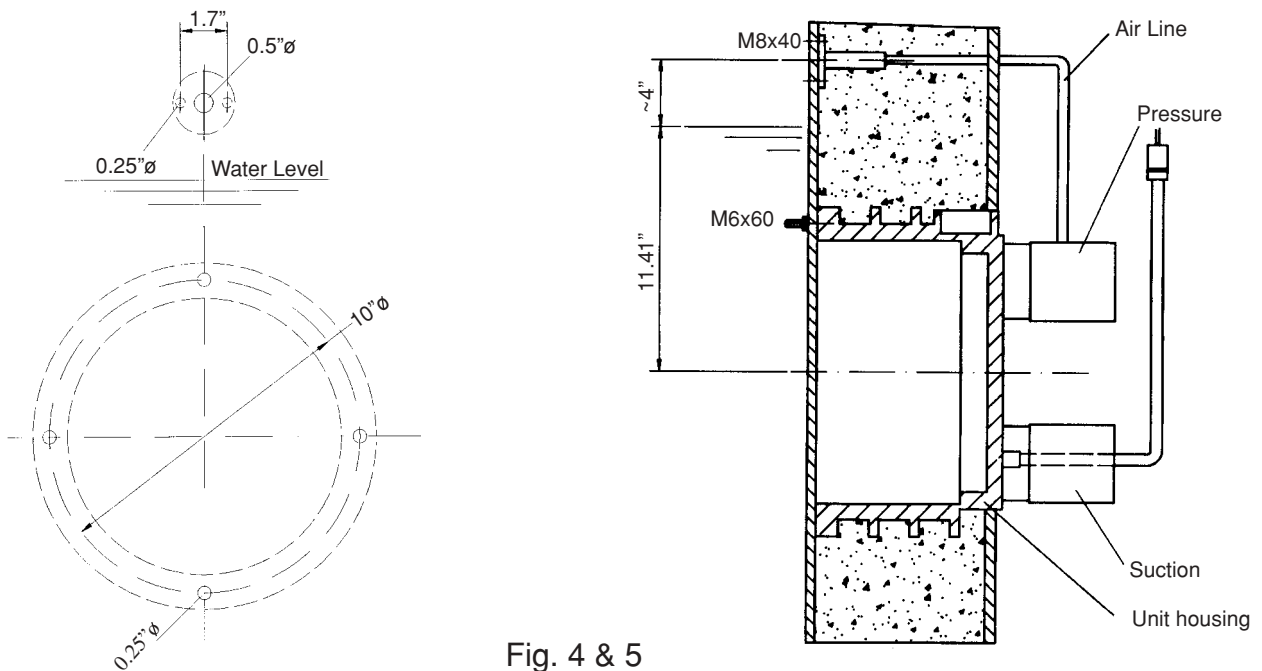

Fig. 4 & 5

3. Liner and or Fiberglass Pool Installation

The center of the housing should be 11.5" BELOW water level for maximum efficiency. Place gasket with knobs (#26) BEHIND pool wall. Place clamping ring gasket (#27) in front of pool wall.

The two holes at 18° from the vertical axis and the two holes (top & bottom) at the air regulator will allow both housing and air regulator to be mounted with counter-sunk bolts (M6) before the liner is placed.

4. Installation of Housing

The **BADUJET** has no control knob, therefore the pre-assembled nozzle housing with jet can be inserted directly into the jet housing. Next, the 6 bolts M6 x 25 (#52) and the 5 bolts M6 x 100 (#51) are screwed into the housing.

All other instructions are the same for both the **BADUJET super-sport** and the **BADUJET CLASSIC**.

PLEASE READ ALL BADUJET INSTRUCTIONS BEFORE INSTALLATION!

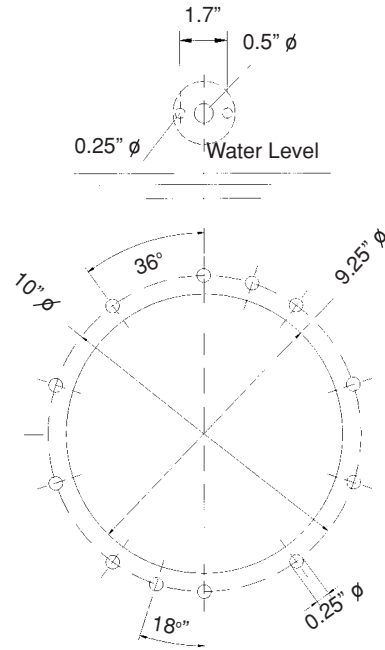

Exploded View for **BADUJET Classic**

Part #	Qty.	Description	Part #	Qty.	Description
1	1	Jet Housing	26	1	Gasket with Knobs - Jet Housing
2	2	Adaptor - Male, Housing PVC 2" X 75 mm /3"	27	1	Gasket - Clamping Ring
3	1	Adaptor - Male, Housing PVC 1/2"	28	1	Ring - Clamping
5	2	Nipple - Hose, Air Regulator, Plastic 1/4"	29	10	Bolt - Clamping Ring, Slot M6 X 25 SS
7	1	Hose - Air Regulator 8 X 3 mm X 1.4 Meters	30	1	Cover - Gunite
8	2	Clamp - Hose, Air Regulator 14/9 SS	31	4	Stud - Gunite Cover, All Thread, M6 X 80
9	1	Holder - Air Regulator	32	4	Washer - Stud, Gunite Cover, Zinc M6
10	2	Bolt - Air Holder, Slot/pan M6 x 30 SS	33	4	Nut - Stud, Gunite Cover M6 SS
11	2	Nut - Air Holder Bolt M6, SS	38/1	1	Pneumatic Button
12	2	Washer - Air Holder M6	40	1	Nut - Pneumatic Button, Plastic
13	1	Gasket - Air Holder 60 X 11 X 2 mm	43/1	1	Cover - Nozzle
16	1	Adaptor - Female, PVC 1/2"	46	1	Clamp - Hose, Pneumatic button 8.7 mm
17	1	Adaptor - Male, PVC 1/2"	47	10m	Air tube 4 X 1.5 mm (per meter)
18	1	Ring - Hose 313/7	49	4	Tapping Screw - Nozzle Cover, Phil. 4.8 X 16
19	2	Washer SS	51	5	Bolt - Nozzle Housing, Slot M6 X 97 mm SS
20	1	Plug - Rubber 7 mm	52	6	Bolt - Nozzle Housing, Slot M6 X 25 mm SS
21	1	Top Part - Air Regulator	53	1	Housing - Nozzle
22	1	Bottom Part - Air Regulator	54/1	1	Nozzle - Adjustable Flow 40 mm
23	1	Bolt W/whole - Air Regulator, Brass M10 X 80	55	1	it Gasket - Tension Cup 103 X 81.5 X 0.6 mm
24	1	Ring - Hose, Air Regulator 16 X 30 X 18 mm	56	1	Seat - Nozzle
25	1	Gasket - air Regulator 42 X 11 X 2 mm	57	1	Spacer - Nozzle 6.2 mm
			58	1	Spacer - Nozzle 1.5 mm
			59	1	Tension Cup - Nozzle
			60	4	Washer - Lock, Tension Cup M6 SS
			61	4	Nut - Tension Cup M6 SS
			62	1	O-ring - Tension Cup 11.3 X 2.4 mm
			68	4	Bolt - Tension Cup, Phillips M6 X 25 mm SS
			80/1	1	Control Box - BJC - 7 - GFCI
			89	1	Massage Hose - 5ft with Pulsator
			89/1	1	Massage Hose - 15ft with Pulsator
			93	1	Cover - Rectangular
			94	4	Washer - Rectangular Cover M6 SS
			95	4	Bolt - Rectangular Cover, Slot M6 x 16 mm
			95/1	4	Bolt - Rectangular Cover, Slot M6 X 60 mm
			96	4	Plug - Rectangular cover
			97	1	Cover - button
			98	2	Bolt - Jet Housing, Slot/pan M6 X 30 mm SS

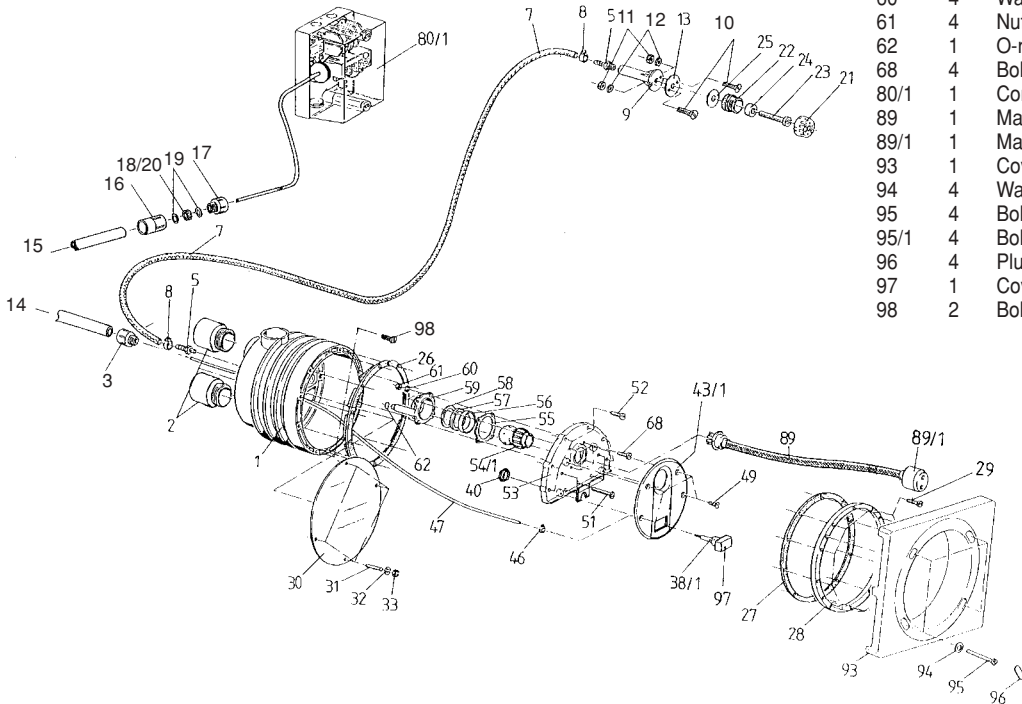

Frequently Asked Questions

What size pool do I need? The **BADUJET** can be installed in any size pool. However, we recommend a minimum length of 14' and a minimum width of a swimming lane.

What size plumbing is necessary? How far away from the **BADUJET can the pump be installed?** Use 4" plumbing up to 30'. For runs longer than 30' use 6" plumbing. The pump can be placed as close to BaduJet as local codes will allow.

How many amps does the pump operate at? Maximum 19.4 amps @ 230 V

What size breaker do I need? You must use a 40 amp breaker to avoid nuisance tripping.

Does it matter if the housing is installed higher or lower than the manual states? Yes, the center of the housing (the two nozzles) should be 10" BELOW water level for proper performance of unit.

Can the air regulator be placed elsewhere? Yes, as long as it is not continuously flooded with water.

What if water is discharging out of air regulator when pump is running? The screws (Part # 51) that mount the nozzle housing (Part # 53) are not fully tightened **OR** o-rings (Part # 62) on the tension cup (Part # 59) are missing or have rolled out of position during installation.

Can the pump be placed below water level? Yes. However, for best performance we recommend ordering pump for flooded suction (Model 21-80/33 G) instead of self-priming (Model 21-80/33 GS). We recommend installing valves for ease of maintenance.

How far away can the air button function properly? A maximum of 50'. Consult factory for distances over 50'.

Do I need to install a motor starter? No. The pump has a built-in thermal overload.

SAVE THESE INSTRUCTIONS!

LIMITED WARRANTY

The manufacturer supplies a limited warranty to the original consumer purchaser of the **BADUJET** on the following terms and conditions:

1. The **BADUJET** is warranted to be free from defects in material and workmanship for a period of twelve (12) months from the date that the **BADUJET** is originally installed.
2. Notwithstanding any provision herein to the contrary, the warranties and obligations hereunder shall not in any event extend for more than 2 years beyond the date of shipment of the **BADUJET** from Speck Pumps-Pool Products, Inc. in Jacksonville, Florida.
3. Warranty is void in the following cases: damages which result in whole or in part from: (a) careless or improper installation of the **BADUJET**; (b) improper or negligent use and maintenance of the **BADUJET**; (c) tampering with the **BADUJET** by unauthorized repair personnel; (d) ground movement; (e) substitution of parts and/or components.
4. The manufacturer's sole obligation hereunder shall be to replace or repair any defective **BADUJET**. The manufacturer reserves the absolute right to determine whether any defective **BADUJET** should be replaced or repaired.
5. Any customer who wishes to make a claim under this Limited Warranty shall notify Speck Pumps, of such claim by telephone or by mail. After the customer has been authorized to return a defective **BADUJET**, the customer must return the **BADUJET** to Speck Pumps.

Any goods returned to Speck Pumps without prior authorization will be returned to the shipper unopened. Speck Pumps shall not bear any costs or risks incurred in shipping a defective **BADUJET** to Speck Pump or in shipping a repaired or replaced **BADUJET** to a customer. Speck Pumps will charge customers for all non-warranty work which it may perform. Warranty work will not be performed until the customer has accepted the price quote.

7. Except as specifically set forth above, no other warranties, whether express or implied, including, without limitation, the implied warranties of merchantability and fitness for a particular purpose, are made by the manufacturer. In no event will the manufacturer be liable for any loss, including time, money, goodwill, lost profits and consequential damages based on contract, tort or other legal theory, which may arise hereunder or from the use, operation or modification of the pump, motor or associated parts. The maximum liability of the manufacturer hereunder shall not exceed the amount actually paid by the customer for the pump, motor and associated parts.

8. Some states do not permit limitations on the terms of implied warranties or on the recovery of incidental or consequential damages. Accordingly, the limitations contained in paragraph 7, may not apply to certain customers. 9. This warranty gives customers specific legal rights. Customers may have other rights which may vary from state to state. The **BADUJET** is manufactured under license from **Speck Pumpen, GERMANY**.

Date of Installation: _____

Installed By: _____

For Service Call: _____
